

High Power PM Optical Circulator 1064nm

The 3 port 1064nm High Power Polarization Maintaining (PM) optical circulator is a fiber optic component built with PM fiber. It allows light to be transmitted in only one direction while blocking the opposite transmission, its light path is port 1 to port 2, and port 2 to port 3. The PM fiber circulator is widely used in optical fiber networks and amplifiers where polarization maintaining characteristics are needed. High Power handling up to 10W is available upon request.

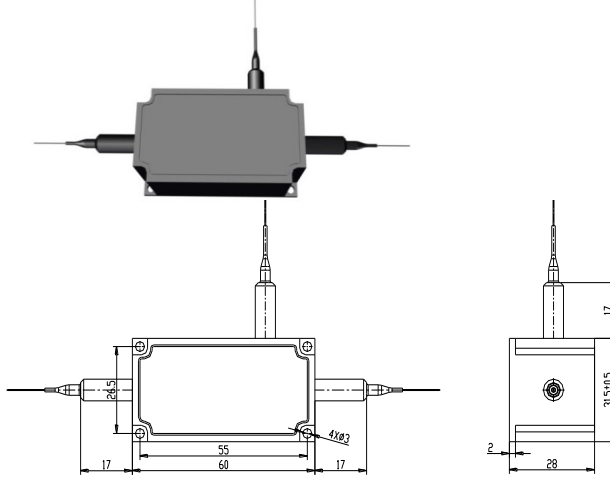

Features

- Low Insertion Loss
- High Isolation
- High Extinction Ratio
- High Power Handling

Applications

- EDFA & Raman Amplifier
- Fiber Sensor
- Dispersion Compensation
- Test & Measurement
- WDM Systems

Performance Specification

Parameter	Value	Unit
Center Wavelength	1064 or customized	nm
Bandwidth	±10	nm
Configuration	1X2, (port 1→2, 2→3)	
Typ. Insertion Loss (port 1→2, 2→3)	1.2	dB
Max. Insertion Loss (port 1→2, 2→3)	1.5	dB
Typ. Isolation (port 2→1, 3→2)	26	dB
Min. Isolation (port 2→1, 3→2)	22	dB
Min. Extinction Ratio	20	dB
Min. Cross Talk (port 1→3)	50	dB
Min. Return Loss	50	dB
Max. Optical Power (Continuous Wave)	1, 3, 5, 10	W
Max. Tensile Load	5	N
Fiber Type	PM 980 Panda Fiber	
Operating Temperature	-5 to +50	°C
Storage Temperature	-40 to +85	°C
Package Dimension	L60×W31.5×H28	mm

Note

* For devices with connectors, IL will be 0.3dB higher, RL will be 5dB lower.

* Connectors only CW 1W handling power guarantee.

* Package may change according to different handling power.

Ordering Information

HPMCIR-AAAA-BB-C-DD-EE-FF

AAAA	BB	C	DD	EE	FF
Wavelength	Port	Fiber Jacket	Fiber Length	Connector	Power
1064 - 1064nm	12 - 1 X 2	B - 250um Bare	05 - 0.5m	NE - None	01 - 1W
SSSS - Specify		Fiber	08 - 0.8m		02 - 2W
		L - 900um Loose	10 - 1.0m		03 - 3W
		Tube	15 - 1.5m		05 - 5W
			SS - Specify		10 - 10W
					SS - Specify