

High Power PM Optical Isolator 1064nm

The 1064nm High Power Polarization Maintaining Optical Fiber Isolator is an in-line pigtailed micro-optic component allows light to be transmitted only in the forward direction while blocking the backward transmission. It features high isolation, low insertion loss and high power handling. The optical isolators are commonly used to protect lasers or amplifiers against back-reflected light.

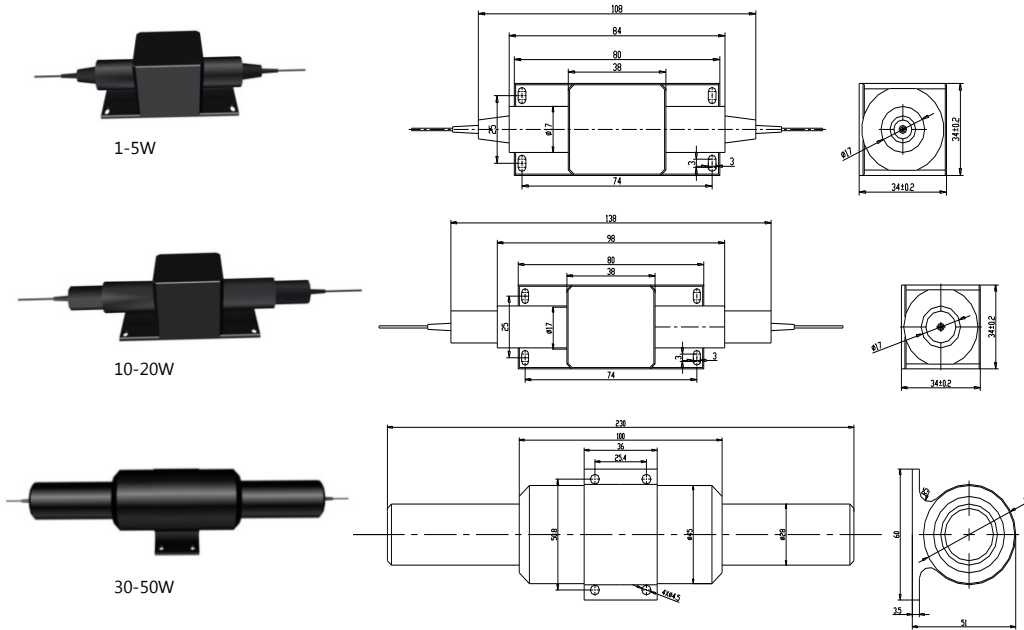

Features

- High Isolation & Extinction Ratio
- Low Insertion Loss
- High Power Handling

Applications

- Fiber Amplifier
- Fiber Laser & Sensor
- Lab & Research

Performance Specification

Parameter	Value	Unit
Center Wavelength	1064 or customized	nm
Bandwidth	±10	nm
Max. Optical Power (CW)	1, 3, 5, 10, 20 30, 50	W
Typ. Insertion Loss at 23°C	0.6 0.8	dB
Max. Insertion Loss at 23°C	1.0 1.2	dB
Typ. Peak Isolation	35	dB
Min. Isolation at 23°C	26	dB
Min. Extinction Ratio	20	dB
Min. Return Loss	50	dB
Max. Tensile Load	5	N
Fiber Type	PM 980 Panda Fiber or PM LMA Fiber	
Operating Temperature	-5 to +50	°C
Storage Temperature	-20 to +75	°C
Package Dimension		mm

Note

- * For pulse applications, pls discuss with OF-LINK.
- * Specifications may change without notice.

Ordering Information

HPMI-AAAA-BB-C-DD-EE-F-GG

AAAA	BB	C	DD	EE	F	GG
Wavelength	Fiber Type	Fiber Jacket	Fiber Length	Connector	Working Axis	Power
1030 - 1030nm	P9 - PM 980 Fiber	B - 250um Bare	05 - 0.5m	NE - None	F - Fast Axis	01 - 1W
1040 - 1040nm	LM - PM LMA Fiber	Fiber	08 - 0.8m		Blocked	03 - 3W
1050 - 1050nm	SS - Specify	L - 900um Loose	10 - 1.0m		B - Both Axis	05 - 5W
1053 - 1053nm		Tube	15 - 1.5m		Operating	10 - 10W
1064 - 1064nm			SS - Specify			15 - 15W
1080 - 1080nm						20 - 20W
SSSS - Specify						30 - 30W
						50 - 50W
						SS - Specify